

SA4550 4-ATI PRIMARY ATTITUDE DISPLAY



The Sandel SA4550 Primary Attitude Display is the perfect update for aging electromechanical ADIs, and an ideal complement to the high-definition Sandel SN4500 Primary Navigation Display.

Featuring Sandel's patented LED display technology, generating a resolution of 200 pixels per inch, the SA4550 provides 180° horizontal and vertical viewing angles. You'll find the SA4550 completely transforms your panel. Reliable, affordable and backed by Sandel's award-winning product support, the SA4550 is ideal for corporate and air transport aircraft.

See what's next

SANDEL.

SA4550 4-ATI PRIMARY ATTITUDE DISPLAY

Drawing from our experience with thousands of compact integrated displays in service, we designed the SA4550 to do what no others can: Replace your electromechanical ADI with a modular electronic unit.

This allows you to update your panel with minimum disruption to your aircraft. And by saving on both acquisition and installation costs, the SA4550 is a cost-effective way to enhance both the operational and the residual value of your aircraft or fleet.

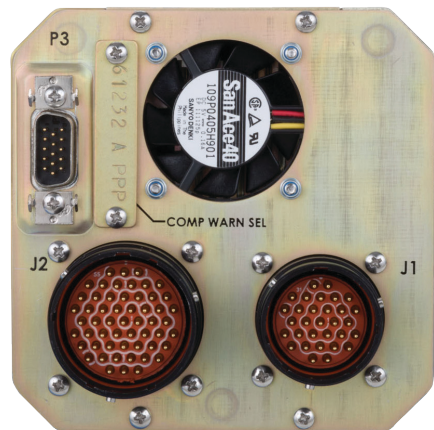

Weight	SA4550	3.4 lb. (1.54 kg)
Bracket & Connectors		0.5 lb (0.23 kg)
Dimensions		
Length		7.82 in. (19.86 cm) from back of bezel (Sperry AD-550 retrofit version) 7.51 in. (19.08 cm) from back of bezel (Sperry AD-600 and AD-650 retrofit versions)
Body		3.975 in. x 3.975 in. (10.084 cm x 10.084 cm)
Bezel		4.060 in. x 4.060 in. (10.312 cm x 10.312 cm)
Display		LED Backlit
NVIS Mode		Class B compatible per MIL-STD-3009
Power Requirements		20-33 VDC 28 VDC @ 1.4A (40W) nominal
Cooling Requirements		Internal fan requiring ambient air at fan input
Mounting		Standard 4-ATI panel cutout with clamp and Sperry compatible connectors Bezel adapters available for mounting in 4x5 and 5x5 panel cutouts

Operating Environment	-20 C. to +70 C. +55,000 ft. max. altitude
Certification Basis	TSO-C113, Airborne Multipurpose Electronic Displays TSO-C3d, Turn and Slip Instruments TSO-C4c, Bank and Pitch Instruments TSO-C34e, ILS Glide Slope Receiving Equipment TSO-C36e, Airborne ILS Localizer Receiving Equipment TSO-C52b, Flight Director Equipment EASA ETSO, 2C34F, 2C36F, C113, C3d, C4c, C52b DO-160E, Env. Cat. [A2F1Z]BBB[HR]XXXXXXXXZZAZ[ZW][WW]M[A3G33]XXAX DO-178B, Software, Attitude Level A, Guidance and Annunciators Level C DO-254, Hardware, Attitude Level A, Guidance and Annunciators Level C

Interfaces	
Attitude	Remote XYZ synchro (ARINC 407) for pitch and roll, ARINC 429*
Attitude Comparator	Analog
Flight Director	Analog
Glidescope/LOC	Analog
Fast/Slow	Analog
Radar Altimeter	ARINC 552, Sperry and Collins
Annunciators	Discrete

*Contact Sandel for ARINC 429 attitude input availability

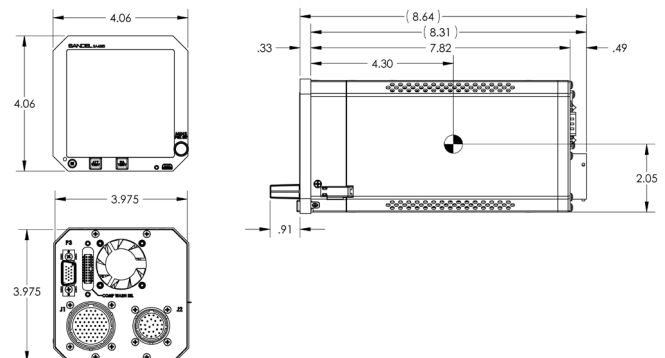

Dimensions and specifications subject to change without notice.